

Nuts

Square

Heavy Style

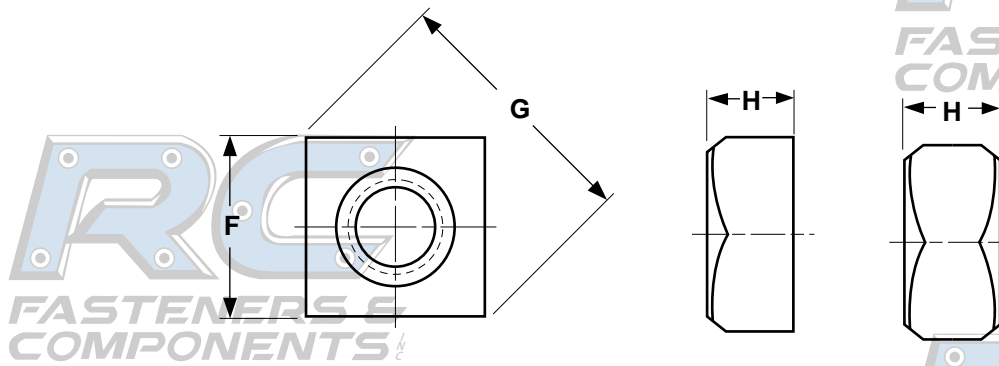

Nominal Size or Basic Major Dia. of Thread		HEAVY SQUARE NUTS						ANSI/ASME B18.2.2
		F		G		H		
		Width Across Flats		Width Across Corners		Thickness		
		Max	Min	Max	Min	Max	Min	
1/4	0.2500	0.500	0.488	0.707	0.640	0.266	0.218	
5/16	0.3125	0.562	0.546	0.795	0.720	0.330	0.280	
3/8	0.3750	0.688	0.669	0.973	0.889	0.393	0.341	
7/16	0.4375	0.750	0.728	1.060	0.970	0.456	0.403	
1/2	0.5000	0.875	0.850	1.237	1.137	0.520	0.464	
5/8	0.6250	1.062	1.031	1.503	1.386	0.647	0.587	
3/4	0.7500	1.250	1.212	1.768	1.635	0.774	0.710	
7/8	0.8750	1.438	1.394	2.033	1.884	0.901	0.833	
1	1.0000	1.625	1.575	2.298	2.132	1.028	0.956	
1-1/8	1.1250	1.812	1.756	2.563	2.381	1.155	1.079	
1-1/4	1.2500	2.000	1.938	2.828	2.631	1.282	1.187	
1-3/8	1.3750	2.188	2.119	3.094	2.879	1.409	1.310	
1-1/2	1.5000	2.375	2.300	3.359	3.128	1.536	1.433	

Description	A four-sided, internally threaded fastener with a washer-faced top side, and a flat or chamfered bottom. They are wider and thicker than regular square nuts.
Applications/Advantages	For use with A307 Grade A or Grade B bolts.
Material	Nuts shall be made from a carbon steel which conforms to the following chemical composition requirements- Carbon: 0.58% maximum; Phosphorus: 0.13% maximum
Hardness	Rockwell B68 - C32
Proof Load	Plain or Zinc-Plated: 90,000 psi.; Hot-Dip Galvanized: 68,000 psi.
Plating	See Appendix-A for plating information.